



PGA



Portable Gas Analyser

Simple, reliable field absolute analyser for a variety of geoscience applications



- Single or dual gas analyser
- Large range of gases
- Battery portable
- Sample pump
- Simple to use

Gases Include:
Carbon Dioxide
Methane
Oxygen
Carbon Monoxide

Selectivity, sensitivity and repeatability

The PGA Portable Gas Analyser is a self-contained portable measurement device for a wide range of geoscience research applications. It is available for measuring a wide number of gases in a wide variety measurement ranges.

One gas, such as CO₂, can be measured by single beam infrared technology providing unparalleled selectivity, sensitivity and repeatability for such a portable device.

For measuring a second gas, such as oxygen the PGA can be fitted with an electrochemical analysis cell.

The PGA features an integral sample pump and an autozero. The PGA is simple to use and calibrate.

RS232 is provided for real time monitoring and recording.

True field portability

The new PGA is the latest addition to the ADC BioScientific range of Geoscience research analysers. Weighing just 5kg and offering 8 hours of continuous use, the battery operated PGA is set to offer new levels in portability and performance for a field portable gas analyser.

CO₂ analysis

Probably the most commonly analysed gas in related geoscience, environmental science and atmospheric science studies is CO₂.

The PGA is available in ranges from 0-2000ppm CO₂ to 0-100% with a resolution of 0.5% full scale deflection (fsd). This corresponds to 10ppm resolution for the 0-2000ppm instrument.

The PGA suitable for a wide range of experimental studies including elevated CO₂ studies, atmospheric CO₂ monitoring, FACE experimentation and measuring high concentrations in natural CO₂ springs.



PGA Gas Ranges

GAS	Symbol	Minimum Range Available		Lowest Detection Limit	
		SB Single Beam Technology	ECC Chemical Cell	SB	ECC
Carbon Dioxide	CO2	2000ppm		10ppm	
Carbon Monoxide	CO	5000ppm	50ppm	50ppm	1ppm
Sulphur Dioxide	SO2	1.0%	50ppm	100ppm	1ppm
Sulphur Hexafluoride	SF6	1000ppm		10ppm	
Nitric Oxide	NO	2%	50ppm	200ppm	1ppm
Nitrous Oxide	N2O	2000ppm		10ppm	
Ammonia	NH3	2.0%		200ppm	
Methane	CH4	1.0%		100ppm	
Ethane	C2H6	1.0%		100ppm	
Propane	C3H8	1.0%		100ppm	
Butane	C4H10	0.5%		50ppm	
Pentane	C5H12	0.5%		50ppm	
Hexane	C6H14	0.5%		50ppm	
Heptane	C7H16	2.0%		200ppm	
Freons	-	2.0%		200ppm	
Oxygen			100ppm		1ppm
Hydrogen	H2		50ppm		1ppm
Hydrogen Sulphide	H2S		50ppm		1ppm



Specification

Measurement technique: Non-dispersive infrared absorption with solid state detector.

Measurement range: Up to 100% for gases and saturation concentrations for vapours.

Resolution: 0.5% fsd

Repeatability: +/- 1.0% fsd

Noise: 0.5% fsd

Span stability: 0.5% fsd over 24 hours

Response time: Typically 4 seconds to T90 dependent on cell size.

Flow rate: Typically 0.2 - 1 litre per minute

Operating temperature range: 5°C - 40°C

Battery: Rechargeable 3.2Ah lead acid allowing 8 hours of continuous operation.

Dimensions: 260 x 80 x 300mm

Weight: 5kg

PGA Gas Circuit with oxygen cell fitted

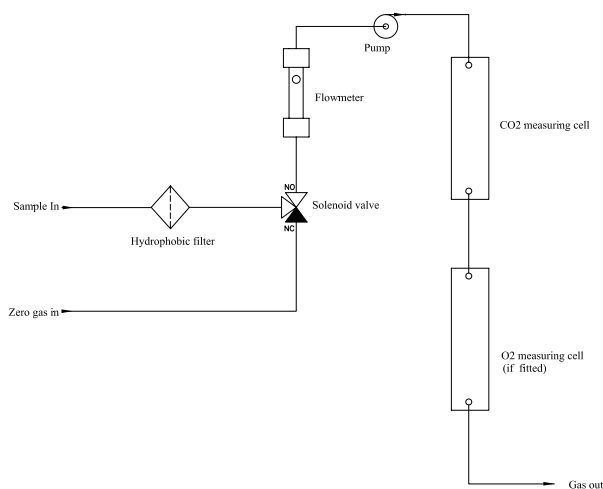

With a Soda Lime column connected to the "zero gas in" fresh air can be used to auto zero the CO₂ analyser and auto span the oxygen cell ensuring long term stability of gas readings.



ADC BioScientific Ltd.

Global House
Hoddesdon
Herts, EN11 0NT
UK

Tel: +44 (0)1992 464527 Fax: +44 (0)1992 444245
sales@adc.co.uk www.adc.co.uk